

FUNDAMENTALS

FASHENIC
STYLE

jump rope

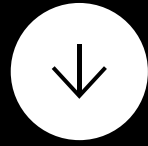



01

INTRODUCTION

The origin of jump rope

How the jump rope improves my health

Jump rope body area focus

02

WHAT YOU NEED TO KNOW

Before you begin: Safety first

On your mark: Getting to know your equipment

Getting ready: Adjusting your rope

Training for the long term:

Taking care of your rope

Tips to start jump roping

Starting: Warmup

03

EXERCISES

Starting point

Single jump

Alternating legs

One-leg jumps

Double hops

Defeat the Gods

Table of contents

01



Introduction



The origin of jump rope

Skipping rope goes beyond its more commonly known use as a fun children's game. While there is no clear answer of when we as humans began using jump ropes,

Drawings from Ancient Egypt and the medieval period show humans jumping rope. When Dutch settlers introduced the activity from Europe to the US, it gradually gained popularity, especially in the 1970s, as an affordable, fun, and effective way to stay healthy and boost physical performance.

Fact: This is where the term "Double Dutch" originates.

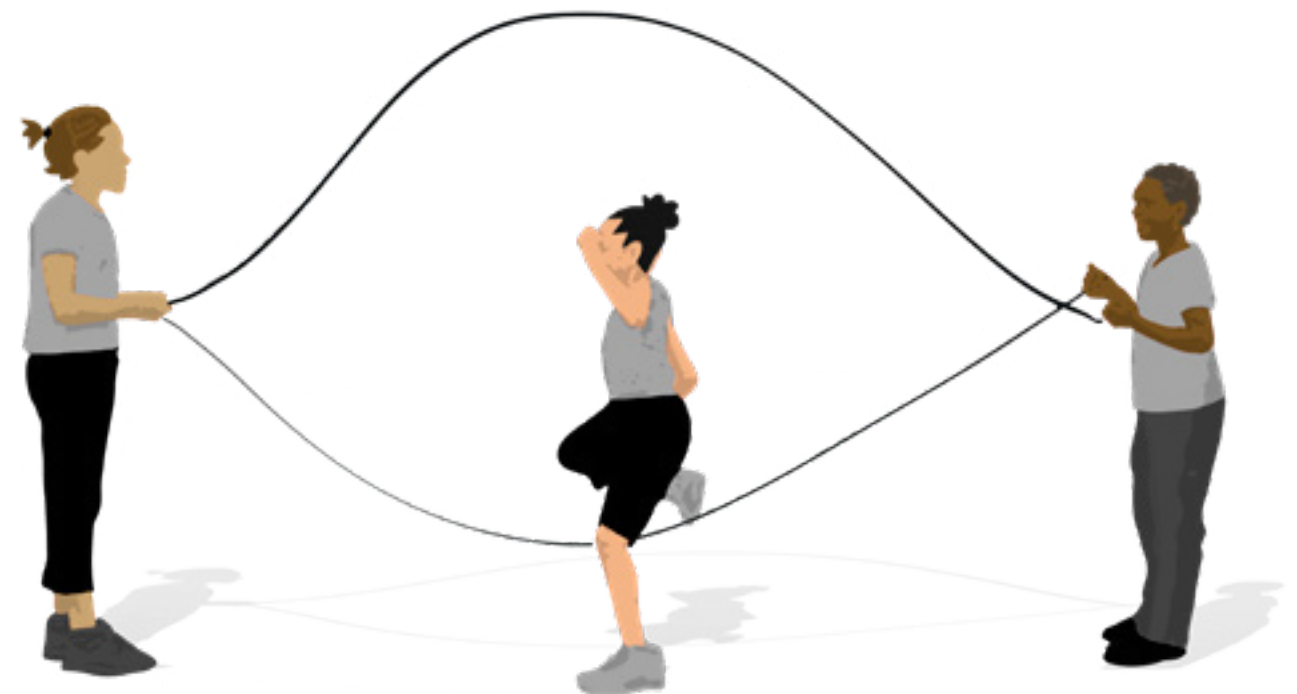

How the jump rope improves my health

To correctly use a jump rope requires performing a fundamental and essential movement; jumping. This movement is part of our evolutionary history as we continuously adapted to ever-changing environments.

Incorporating a jump rope into your training routine results in several health benefits, both mentally and physically.

FOR BODY AND MIND

Jumping rope enhances overall strength by boosting cardiovascular fitness, muscular endurance, and mobility. Beyond physical conditioning, it also strengthens the connection between body and mind by improving coordination, proprioception, and focus. Proprioception refers to your awareness of your body's position and movement in space. These abilities carry over into everyday Free Athlete activities, enabling you to become stronger, more agile, and mentally sharper.



FURTHER BENEFITS OF JUMP ROPE

Additionally, jump roping is an effective way to burn calories, activate your cardiovascular system, and engage many muscles of your body.

Portable, versatile, and lightweight, a jump rope will fit perfectly in your Rainshield gym bag, and can be used to add variety to your training.



Jump rope body area focus

When used properly, a jump rope can serve as a complete workout that engages several muscle groups.

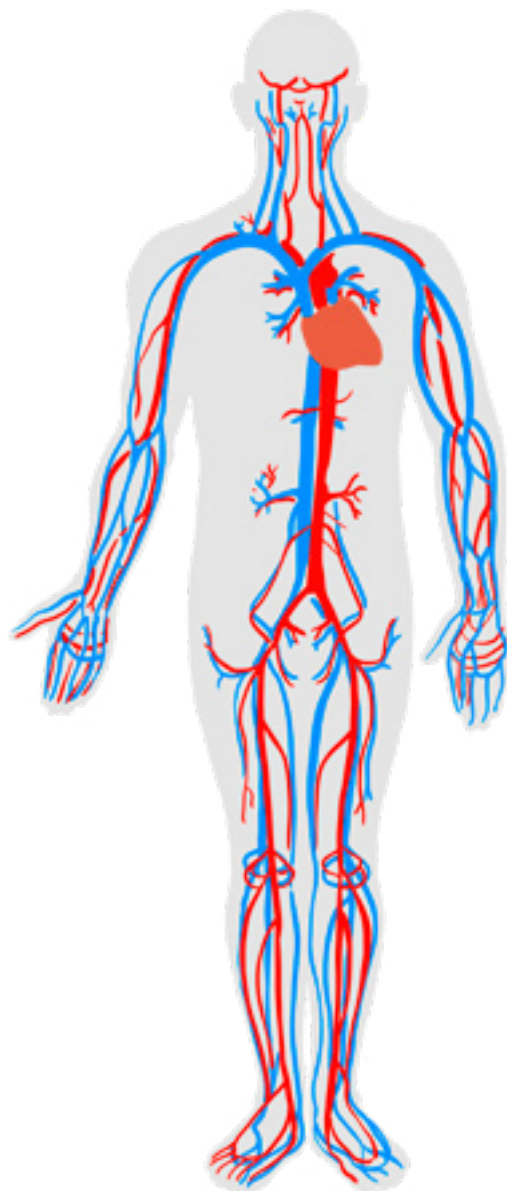

CARDIOVASCULAR SYSTEM

The various methods of jump roping serve as one of the most effective ways of strengthening your cardiovascular system and improving your overall endurance. A healthy cardiovascular system is a fundamental pillar of a healthy body.

CORE

Jump roping engages your core. In order to jump continuously, a tight core and strong lower back muscles and glutes are necessary.

Jump roping will help you build a strong core and increase endurance in the lower body.



GRIP, FOREARMS, AND SHOULDER

While jump roping primarily reinforces the lower body and the core, it also improves upper body endurance. For example, the forearm and wrist muscles are continuously needed to rotate the rope - and the shoulders are engaged for double-unders.

CALVES

Performing high-repetition jump rope sessions helps develop strong, enduring calves. These muscles, focused on endurance, are crucial for numerous everyday movements. Located at the base of the body and engaged with every step, well-developed calves enhance stability, support higher jumps, and allow you to sustain repeated jumping for extended periods.

02



What you need to know



Before you begin: Safety first



CLOTHING AND FOOTWEAR

In order to train safely, proper clothing and footwear is essential.

Proper footwear consists of regular training shoes and comfortable sports socks.

Proper clothing should be lightweight and fitting while allowing free range of motion. There should be no discomfort, and your clothing should not risk getting caught in the rope.

BEFORE EACH SESSION

Prior to each session, verify that your jump rope can be safely used.

TRAINING IN A SAFE AREA

For your safety, be sure that your rope can move freely around you without any obstacle in the way. If you are training indoors, be sure that the ceiling is high enough so as not to interfere with the rope.

On your mark: Getting to know your equipment

The aim of this E-book is to provide you with all relevant information in getting started with your jump rope. To do so, it also helps to understand the equipment you're using. Our Essentials jump rope gives you the opportunity to train and progress anywhere and at any time.

HANDLE

Weight (per pair) of 105g (+/-).

Our team put in the research and work so as to build a jump rope with just the right balance. The handles are ideally weighted so as to support your wrists with rotational movements.

The randed Essentials jump rope features a classic cable designed for speed ropes. Its 2.5 mm diameter, combined with synthetic and steel materials, allows for fast rotation. It's suitable for users of all skill levels.

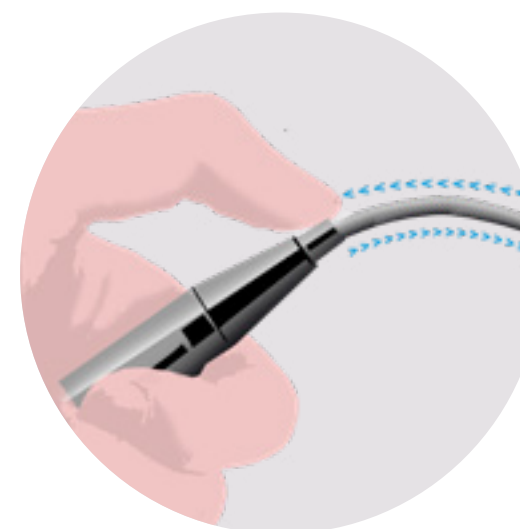
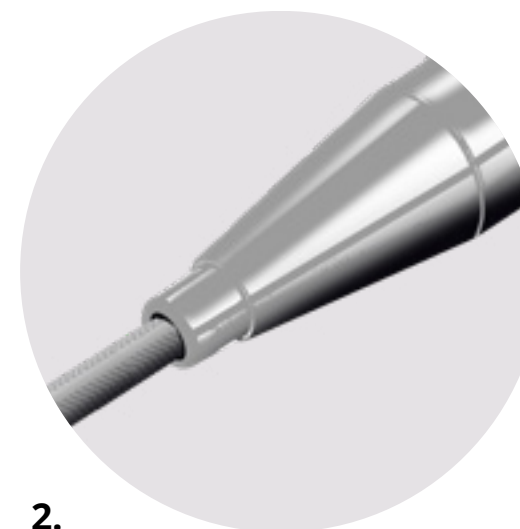
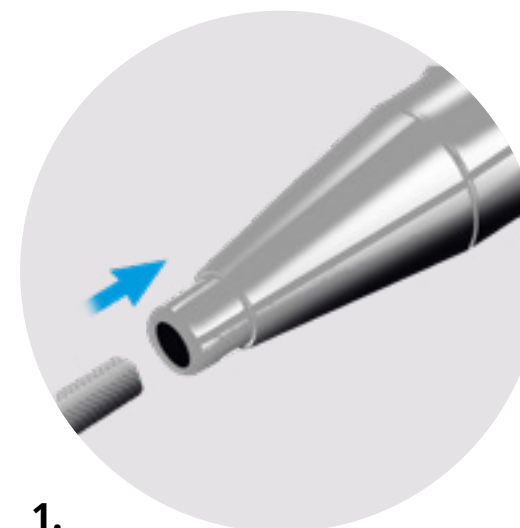

CABLE LENGTH ADJUSTMENT

For greater versatility and flexibility, an adjustable cable was selected, allowing the length to be easily changed at any time. Unlike many ropes that come in a fixed length, the 3-meter Essentials rope can be adjusted whenever needed. Adjusting is simple—just push or pull the cable through the handles. If a shorter length is required, the rope can be securely locked at the desired size within the handles.



Getting ready: Adjusting your rope

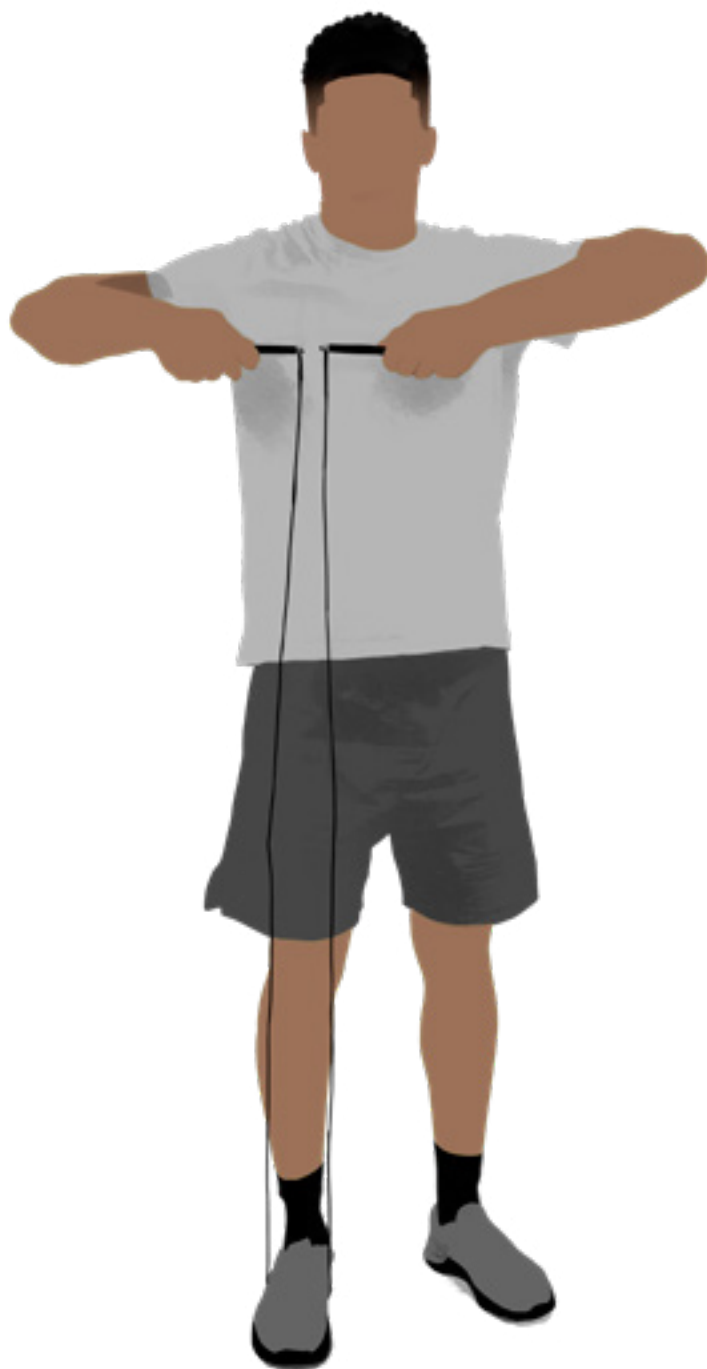

SET UP / ADJUSTING THE ROPE TO THE RIGHT LENGTH:

1. Wear shoes that you will train in.
2. Step with 1 foot onto the cable so that handles are parallel to each other.
3. Turn handles horizontal and adjust length so that handles end just under your armpits.
4. If necessary, adjust the length of the cable by pushing onto the silver metal tips of the handles. Once pushed down, pull out the wire to lengthen the cable or push in the cable to shorten it. The lid at the bottom of the handle can be twisted open in case the cable needs to be further shortened.

ADJUST GRIP TO PERSONAL PREFERENCE:

Grip tape can be used to make a thinner handle a little thicker to better fit your hand or to add extra grip for sweaty hands.

Training for the long term: Taking care of your rope

CLEANING

To clean your jump rope and the handles, simply wipe with a moist cloth.

STORAGE

To keep your jump rope in optimal condition, proper storage is essential. Simply throwing it into your training bag can cause small damages that, over time, may make the rope unusable.

Rather, coil your rope into circles and fix it with a rubber band at the handles before placing it into a small jump rope bag.

USAGE FOR LONGER LIFETIME

To ensure that your jump rope lives long, use it only on hardwood, polyurethane, vinyl, or rubber floor surfaces or even a special mat for jump roping.

Concrete or asphalt surfaces will wear down the rope's coating over time.

BALL BEARINGS

If the ball bearing in your jump rope handle is running a bit rough, give it a drop of oil.



Tips to start jump roping:



1. FIND YOUR PACE

If you're new to jump roping, finding the right rhythm can be a challenge. As an exercise, bounce on your toes and count to 5. Practice this at a steady rhythm without a rope.

2. BREATHING TECHNIQUE AND POSTURE

Like any physical exercise, proper breathing is essential. Breathe in steadily through your nose and mouth, and exhale through your mouth, while keeping your head up and shoulders relaxed.

3. WRISTS POSITION

Keep your wrists open and relaxed with your thumbs on top of the handle to allow a fluid movement and more control.



4. MOVING YOUR WRISTS

For optimal momentum and quick rotation, slide your wrists side to side instead.

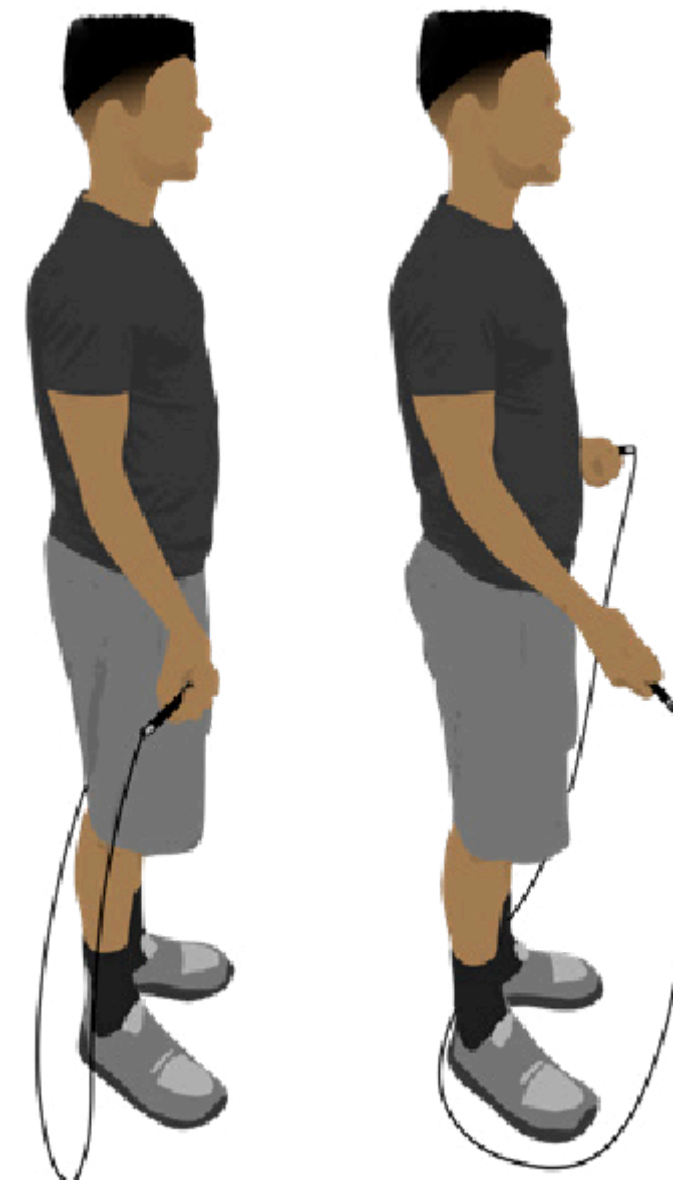

Starting: Warmup

Now, it's time. Prepare yourself mentally for this session. At the moment, your training is all that should be on your mind.

Start with 5 large breaths and focus on the moment. Free Athlete, you're ready.

Every good warmup should start with some sort of cardiovascular activation. For example, you could do some skipping jumps or Jumping Jacks. It is a warmup, so perform controlled movements. Do not focus on speed.

Next, mobilize the different joints that you will use during your workout. Rotate your wrists and ankles. Five rounds in each direction. Lastly, you can focus on the muscles that are specifically targeted by jump roping. Perform some controlled repetitions of exercises like Squat Jumps or Calf Raises.

THE WARMUPS:

1. Wrist Rotations 10x
2. Skipping Jumps 20x
3. Jumping Jacks 20x
4. Squat Jump 10x
5. Calf Raise 20x

WRIST ROTATIONS / ANKLE ROTATION

Be sure to warm up the joints most involved in jump roping—especially the wrists and ankles. Focus on proper preparation by rotating them clockwise and counterclockwise, performing each ankle individually.



Wrist Rotations
10x clockwise and
counterclockwise

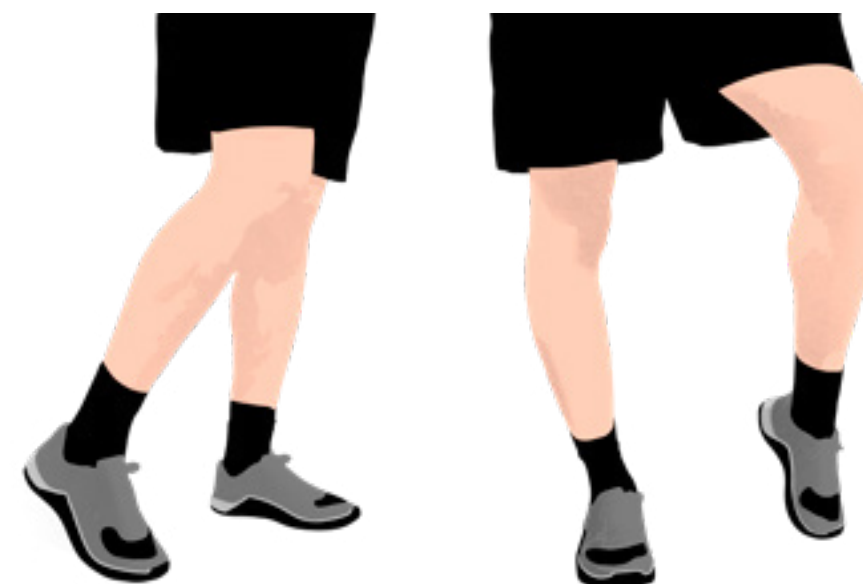

Ankle Rotation
10x (per ankle)
clockwise and
counterclockwise



02 What you need to know

SKIPPING JUMPS / JUMPING JACKS

These exercises gently warm up the entire body, similar the jump rope. The Jumping Jacks add a coordination component that also apply to properly jump roping.

Skipping Jumps
20x



Jumping Jacks
20x



Squat Jumps
10x

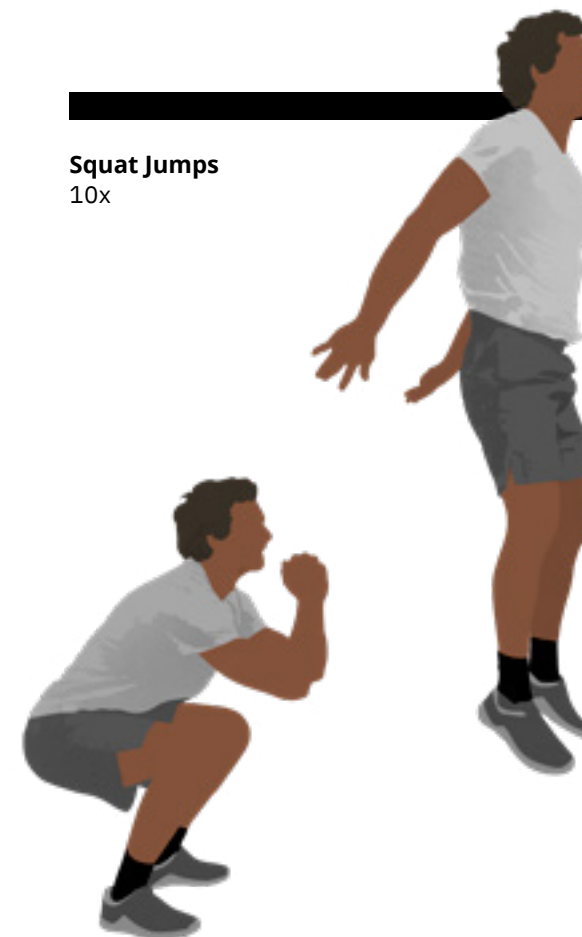

Calf Raises
20x



SQUAT JUMPS / CALF RAISES

Finish off your warmup routine with some Squat Jumps and Calf Raises. These prepare your body for the jumping aspect of jump roping. For the Calf Raise, put one hand on a wall to keep your balance.

03



Exercises



Starting point

Start all your jump rope sets standing upright, the rope behind you, with your arms close to your body. Don't forget that the movement is initiated by your wrists, not your shoulders!



Single jump

This is the most common jump rope exercise. Simply jump once as the rope passes under you.

Once you feel more comfortable, you can play with the rope's speed. This will automatically alter how high or low you jump. Remember, you don't need to jump too high, but rather just high enough so as to not trip on the rope! Your feet should only minimally leave the floor.



Alternating legs

This is a slightly more advanced jump rope variation that challenges your coordination. Keep only one foot on the ground at a time, alternating with each jump. Find a steady rhythm and start!

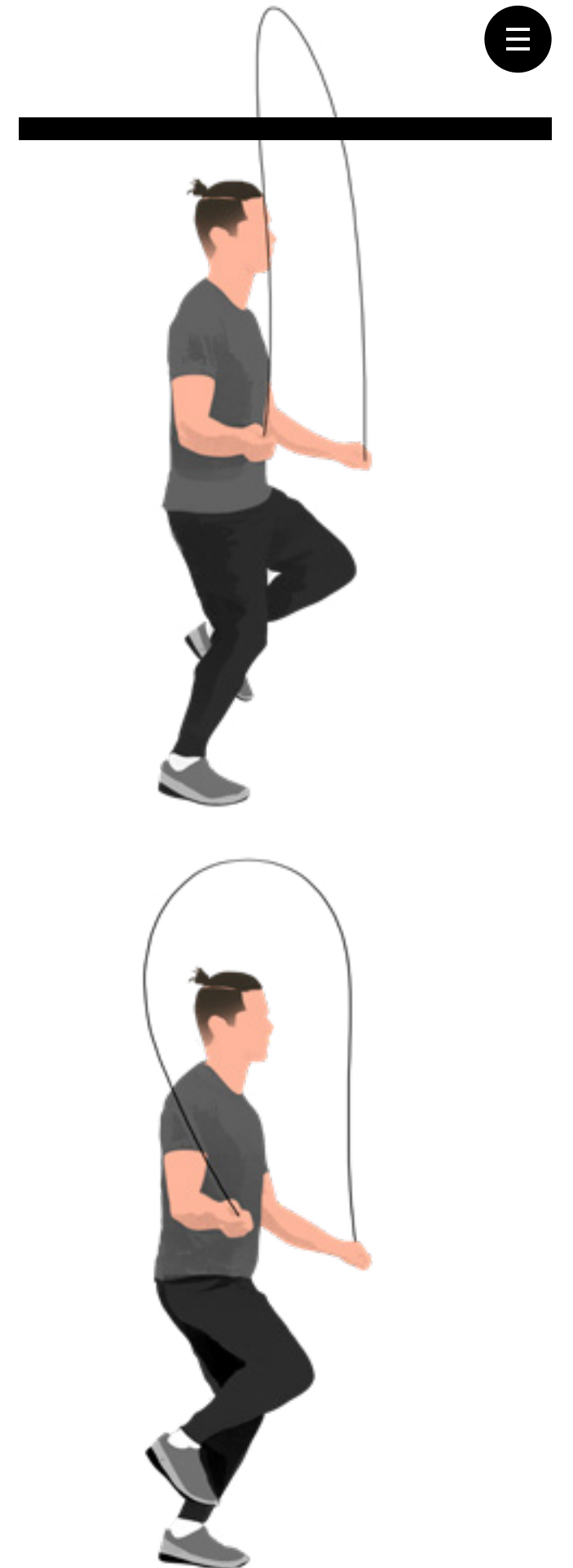

One-leg jumps

This one is a sure way to feel a nice burn in your calf muscles! Make sure to equally do both legs! Contract your core more than usual, as in all unilateral exercises!

Single leg left



Single leg right



Double hops

Double hops are most likely the first variation of jump roping that you will try. It consists of 2 tiny jumps before the rope passes under you, and one jump over the rope. This is a useful exercise to become familiar with the rope and properly time yourself for the jump.

1. One jump over the rope
2. Two hops over the rope



Defeat the Gods

Some of our new iconic God workouts include exercises using a skipping rope. You can find them in your explore tab. Are you ready to take on the challenge?

___ OCNUS

___ DEINO

___ ENYO

___ PEMPHREDO

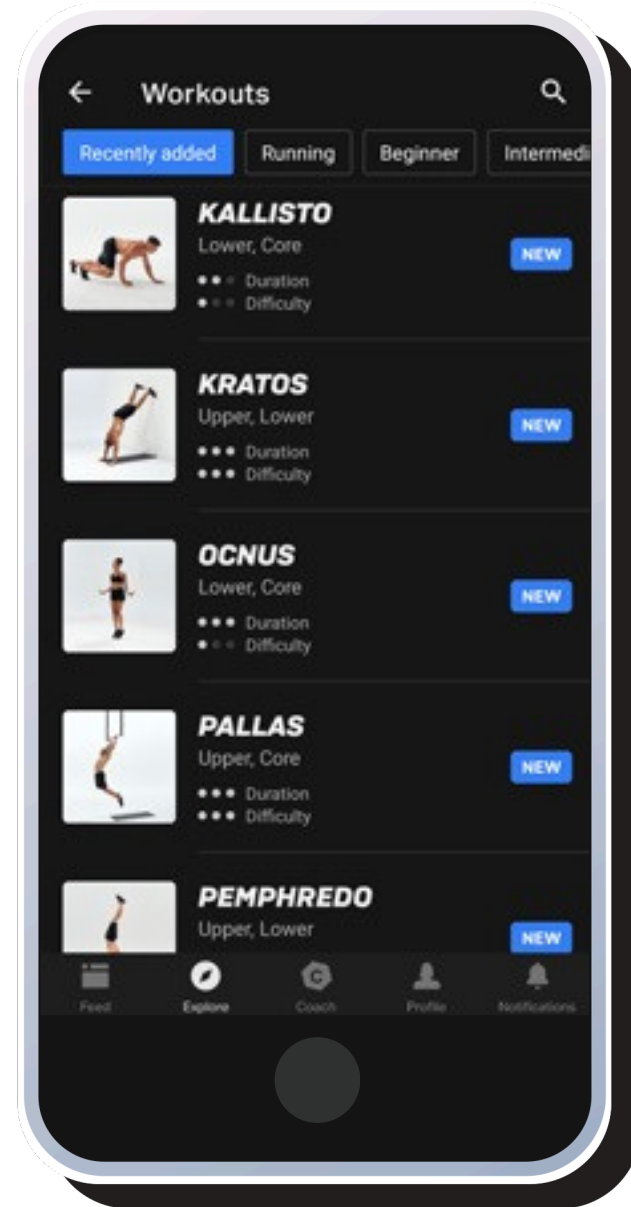

**FASHENIC
STYLE**

**Fashenic Style,
Sheridan, Wyoming,
United States**

www.fashenicstyle.com